

Anti-Collision Radar on Car Bumper

Anti-collision system (or collision avoidance system) is a safety system found in cars which detects danger and reduces possibility or severity of collision. After the danger on the road is detected, the system warns the driver and/or acts and influence moving of a car.

In this application note, we consider anti-collision system which uses radar at 77 GHz. The results from simulations of anti-collision radar antenna mounted on a car bumper will be presented.

The presented problem (anti-collision radar antenna on car) is electrically very large. Thus, the simulations will be performed using Domain Decomposition Solver (further, DDS), a WIPL-D product, dedicated to simulating electrically very large problems.

DDS solver enables full wave solution of electrically very large structures. It was created to solve structures which would otherwise be impossible to solve using WIPL-D Method-of-Moment (further, WIPL-D MoM) solver or solving the structures using WIPL-D MoM solver would require impractically long simulation time.

The basic idea behind DDS is that the original model is decomposed into a number of groups. A group is composed of a number of neighboring plates and wires. Each group represents a subproject. In the 0th iteration, subprojects are simulated independently and the coupling between them is not taken into account. Solutions of all subprojects are used as macro-basis functions whose weighting coefficients are determined from the condition that mean-square value of the residuum of the original project is minimized. The residuum of the final solution in the 1st iteration can be used as the excitation in the 2nd iteration, and so on. The entire iterative procedure finishes when the total residuum falls below the predefined threshold.

Radar Antenna

The anti-collision radar antenna was created from the scratch using WIPL-D software. The antenna is modeled using 4x4 patch array. The antenna model is shown in Figure 1.

Due to the symmetry of the antenna, only half of the antenna was modeled. This reduces the complexity of the structure and increases the numerical efficiency of the simulation.

Calculated radiation pattern of the antenna in $\theta = 0$ plane¹ is shown in Figure 5.

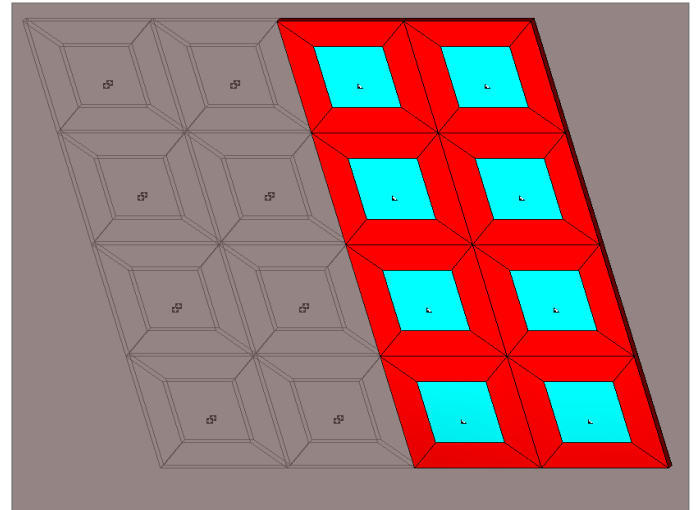

Figure 1. Anti-collision radar antenna – WIPL-D Pro

Radar Antenna on the Bumper

The model of the bumper was imported to WIPL-D Pro CAD and the patch array has been added to emulate a real-world antenna placement scenario. The CAD model of the bumper together with the antenna is shown in Figure 2. The patch array is magnified and highlighted so its position can be easily visualized.

The bumper was modeled using PEC material.

Model of the bumper with the antenna array, after applying the meshing process, is shown in Figure 3.

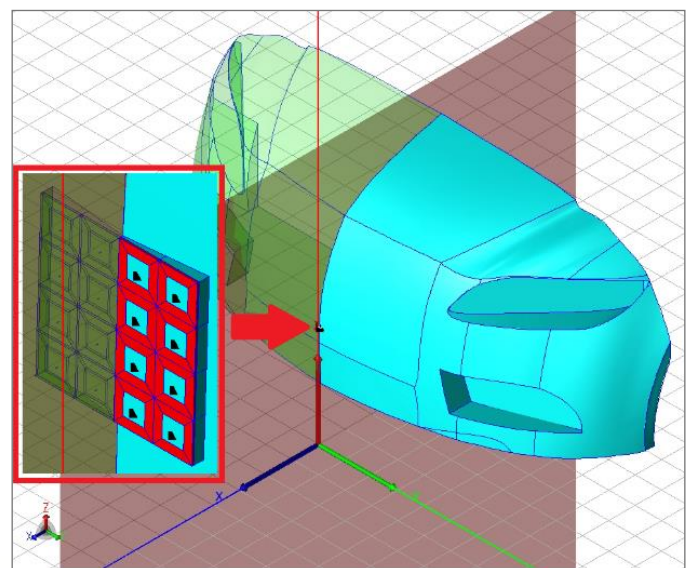

Figure 2. Anti-collision radar antenna mounted on the bumper – WIPL-D Pro CAD

¹ In WIPL-D, this is $z=0$ plane.

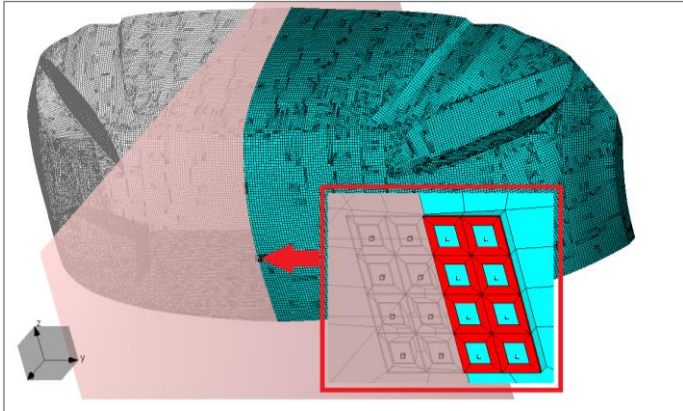

Figure 3. Anti-collision radar antenna mounted on the bumper – WIPL-D Pro

Simulations, Results and Computer Platform

The model of radar antenna on the bumper was simulated at 77 GHz. To ensure high accuracy, parameter *Integral Accuracy* has been set to *Enhanced 1*, and parameter *Max Patch Size* to 1.83.

Results of five simulations carried out using DDS are presented – three simulations without any reduction, and two simulations with the reduction applied. The three simulations without reduction represent three DDS iterations. The remaining two simulations represent two DDS iterations with *smart reduction* applied (*Antenna placement reduction* set to 70%).

Results obtained in simulations are shown in Figure 5.

Simulations were performed with groups which size was equal to 3000 unknowns (Figure 4). The simulation time and a number of unknowns per iteration are presented in Table 1.

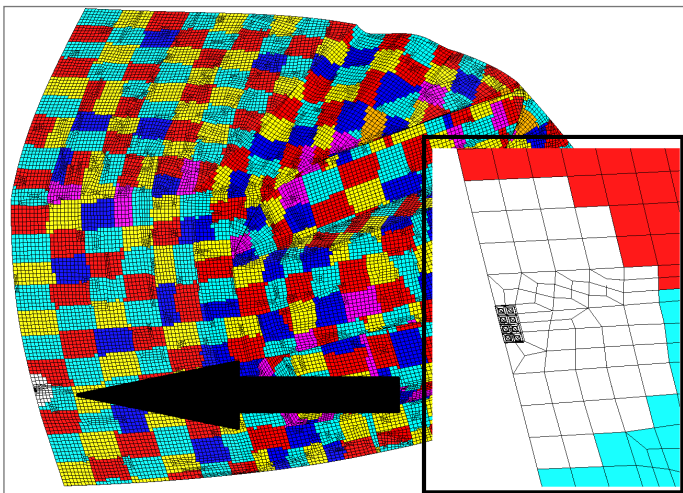

Figure 4. Antenna and the groups – DDS preview

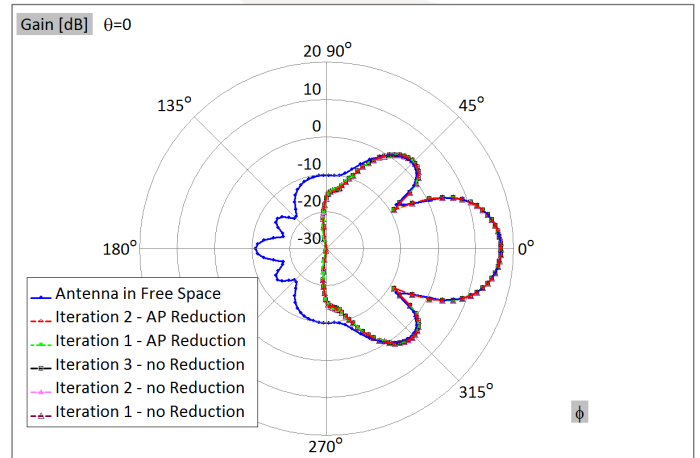

Figure 5. Radiation patterns of the anti-collision radar antenna in free space and anti-collision radar antenna mounted on the bumper

Regardless whether the *Antenna placement reduction* has been applied or not, a value of the residuum was approximately 10^{-4} after the first iteration.

Table 1. Iteration, simulation time and number of unknowns

Model	Iteration	Simulation time [minutes]	Number of unknowns
Without Reduction	1 st	41 (0 th + 1 st)	~2.5 Millions
Without Reduction	2 nd	12	
Without Reduction	3 rd	11	
70% Antenna Placement Reduction	1 st	30 (0 th + 1 st)	~1 Million
70% Antenna Placement Reduction	2 nd	20	

Computer used for these simulations is Intel® Xeon™ CPU E5-2660 v2 @2.20 GHz, 2 processors with 256 GB RAM.

Conclusion

This application note presents a 3D EM model of an anti-collision radar antenna on a car bumper. All the simulations have been performed using DDS, a WIPL-D product dedicated to simulations of electrically very large structures.

All of the simulations have been performed on a powerful desktop machine with two 12-core CPUs and significant amount of RAM. Simulation error and simulation time have been analyzed and compared. The comparison confirms that DDS is a very powerful tool which enables fast and accurate simulation of electrically very large problems. In the particular antenna placement problem, calculated residuals and radiation pattern diagrams confirm that even the results of the first iteration are very accurate.