

Microwave Circuits Design in WIPL-D Microwave

Introduction

Simulation of microwave circuits presents a challenge for modern computational software. Using full-wave EM analysis is not a recommended option for the starting calculations because that kind of analysis involves usage of great amount of memory and requires much simulation time. Thus, in circuit solvers, all circuit elements are modeled by predefined library components whose calculations are performed faster than calculations in full-wave EM analysis, even over a wide frequency range.

WIPL-D Microwave

WIPL-D Microwave is software package which serves as fast and accurate design and simulation tool for projects involving microwave circuits, components and antennas. It is integrated with WIPL-D EM solver, WIPL-D Optimizer and WIPL-D Time Domain Solver. Its user-friendly schematic capture allows easy circuit modeling, importing data in Touchstone format... Component library includes closed-form models in four implementation technologies:

- Microstrip,
- Coplanar waveguide,
- Rectangular waveguide,
- Coaxial...

In addition, lumped elements and many idealized device models are available.

WIPL-D Microwave enables accurately extracting circuit parameters for 3D EM analyzed structures. Using of-the-shelf predefined library components or interactively building user's composite metallic and dielectric 3D models is allowed.

In performing circuit level simulations, the circuit parameters of included 3D EM components are computed on-the-fly.

WIPL-D Microwave can develop complex structures as:

- RF and microwave filters,
- Matching structures,
- Resonators,
- Directional couplers,
- Power dividers,
- Connectors...

Simulation Examples

MW circuits shown in Figure 1 and Figure 3 are analyzed using WIPL-D Microwave.

Circuit shown in Figure 1 is implemented in rectangular technology. It represents single-stub tuner with rectangular waveguides. All of the circuit parameters are optimized in such way that circuit is matched at 10 GHz.

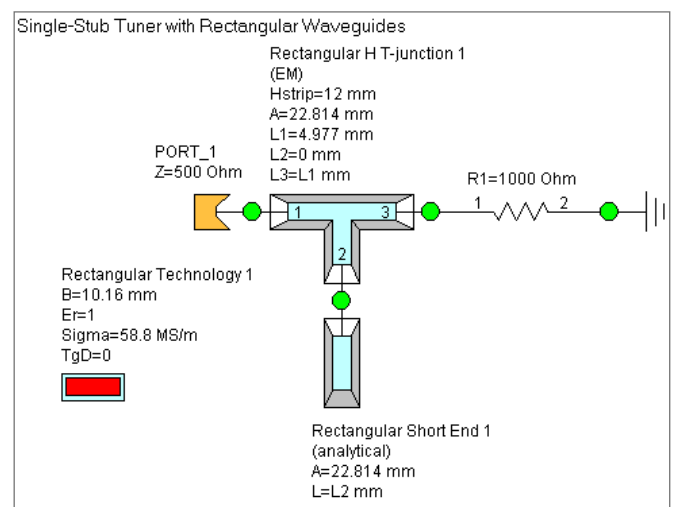

Figure 1. Single-stub tuner with rectangular waveguides

Parameter s11 is shown in Figure 2.

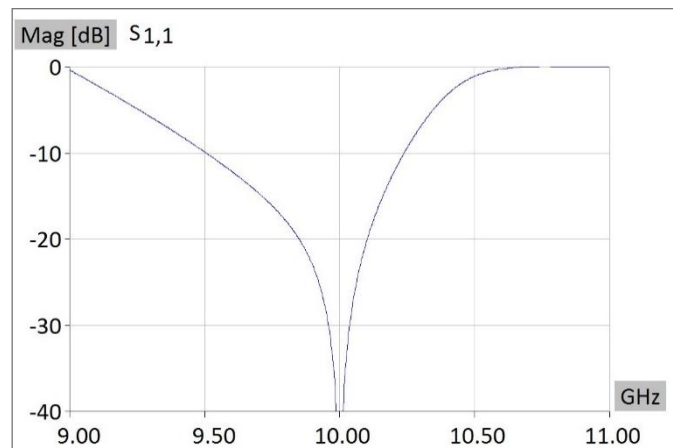

Figure 2. Parameter s11 for circuit shown in Figure 1.

Circuit shown in Figure 3 is implemented in microstrip technology. It is a diplexer.

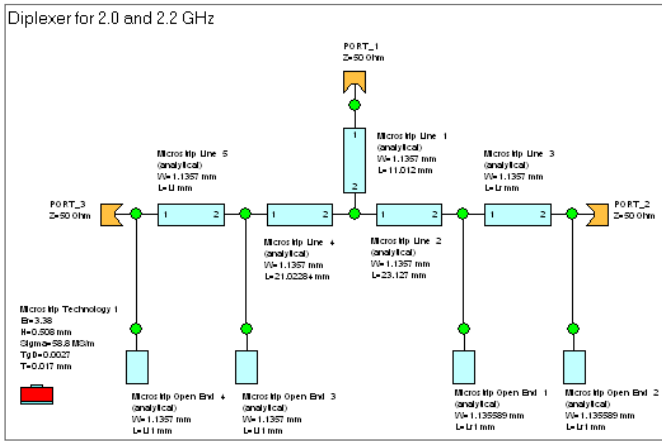

Figure 3. Diplexer

Diplexer is set for operating at 2 GHz and 2.2 GHz. Parameters s_{11} and s_{21} are shown in Figure 4.

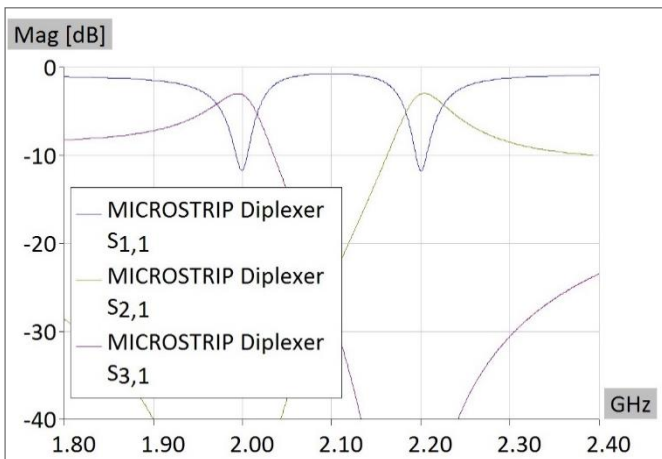

Figure 4. S parameters for network shown in Figure 3.

Circuit shown in Figure 5 is implemented in coaxial technology. It represents Chebyshev impedance transformer. All of the circuit parameters are optimized in such way that circuit is matched in wide band: from 2 GHz up to 8.5 GHz.

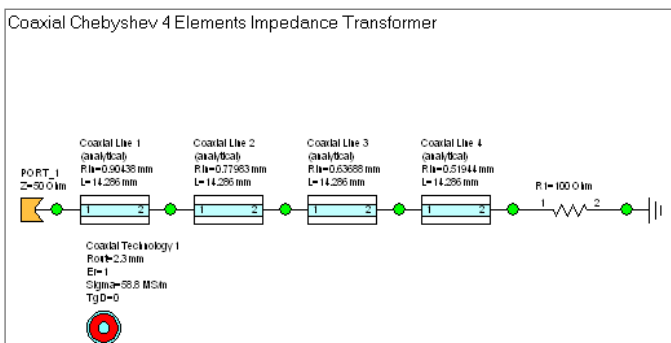

Figure 5. Coaxial Chebyshev impedance transformer

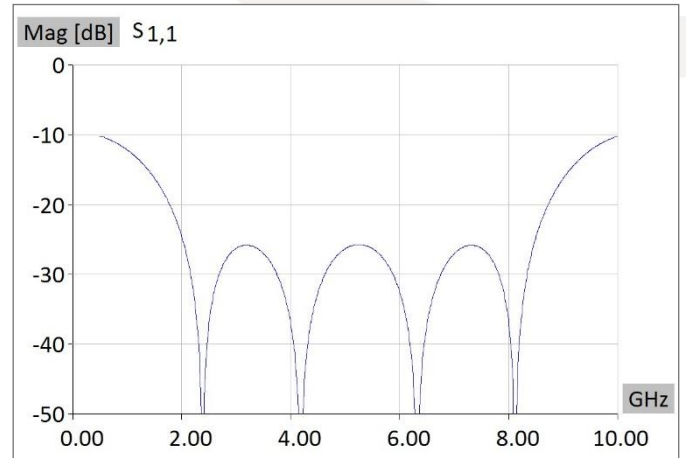

Figure 6. Parameter s_{11} for network shown in Figure 5

Computer required for these simulations is any standard desktop or laptop PC.

Conclusion

Simulation of complex microwave circuits presents a challenge for modern computational software. Using circuit level analysis is recommended option for the starting calculations in order to get results quickly. Thus, in circuit solvers, all circuit elements are modeled by predefined library components whose calculations are performed faster than calculations in full-wave EM analysis, even over a wide frequency range.

WIPL-D Microwave is fast, accurate and easy-to-use software tool, what is proofed in given simulation examples. WIPL-D Microwave is compatible with many other software tools because of supporting Touchstone format.

Complex structures with many elements can be successfully modeled in WIPL-D Microwave.