

Waveguide Slot Array

Slotted waveguide arrays consist of a number of slots cut into the walls of a waveguide forming an array with the slots acting as individual radiating elements.

The resonant slot array employs near half-wavelength long resonant slots as individual radiators. The array elements are excited in the standing wave mode, which is formed by a short circuit end of the waveguide.

The specific design task here is a 10-element transversal slot array cut into the upper wide side of a WR-51 standard rectangular waveguide. The operating frequency is the center of the K band, 18.5 GHz. The dimensions of the waveguide cross-section are $A=0.51$ inch= 12.95 mm, and $B=0.255$ inch= 6.477 mm.

Single Slot Simulation

TE_{10} waveguide mode is excited by a coaxial probe, modeled by a wire segment $\lambda/4$ from the waveguide end, as shown in Fig.1. Slot is cut into the upper waveguide side, at the point where surface currents would otherwise be longitudinal.

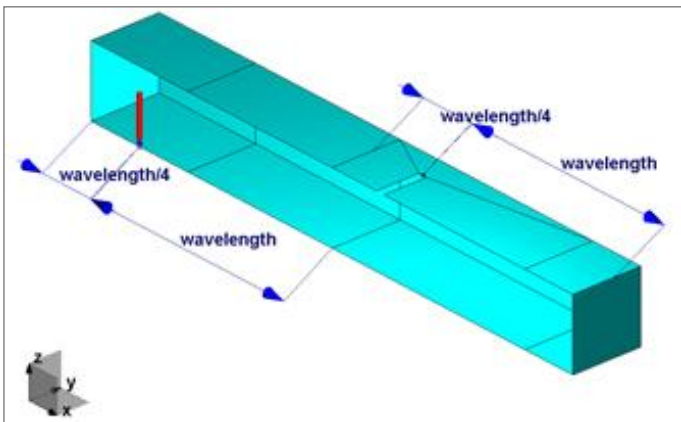

Fig.1. Model of one waveguide slot – one symmetry plane

Only half of the waveguide is modeled, due to symmetry. The complete model is shown in Fig.2.

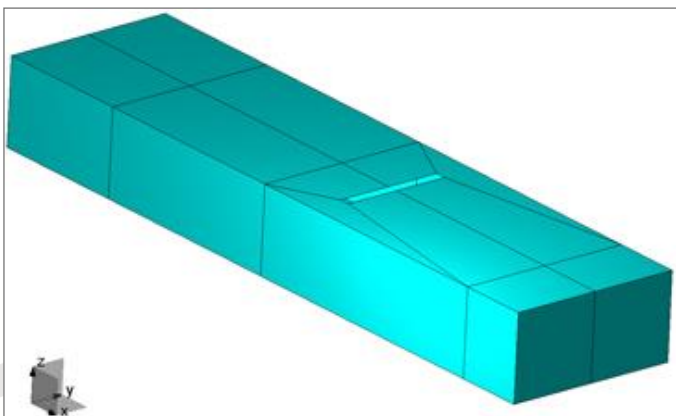

Fig.2. Complete model of waveguide slot

The real part of the longitudinal component of the Poynting vector calculated along the axis of the waveguide shows the transfer of power from the generator to the slot (Fig.3). The first marker is set to the position of the wire-probe feeder, while the second marker is at the position of the center of the slot.

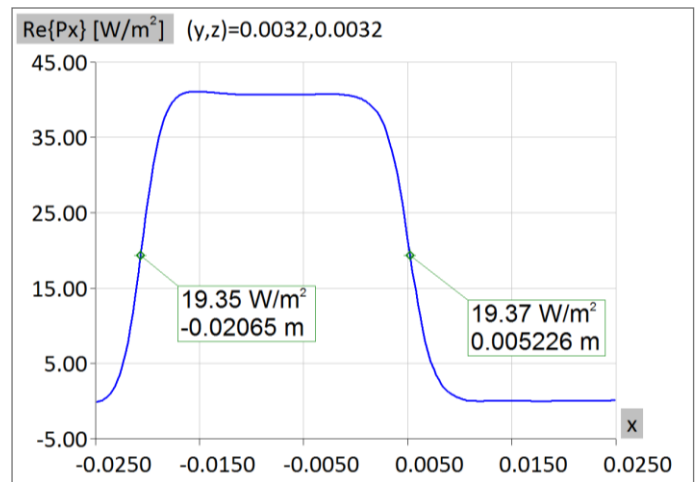

Fig.3. Real part of the Poynting vector longitudinal component along the axis of the waveguide (one slot)

The radiation pattern (in dBi) of a single slot is shown in Fig.4. Only radiation pattern in half-space has been shown here for reasons of clarity, even though full radiation pattern was calculated.

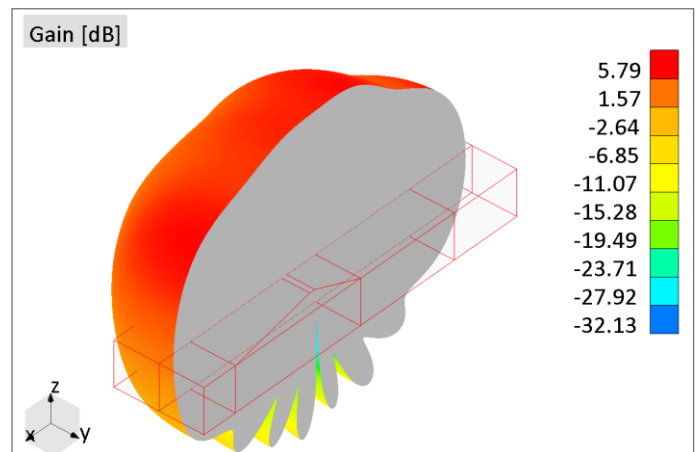

Fig.4. Radiation pattern in half-space of a single slot

This model requires **only 231 unknowns** thanks to higher order MoM applied in WIPL-D Pro 3D EM Solver. The simulation of a single slot including calculation of radiation pattern in 2701 directions and near field in 209 points **took under a second** on a standard desktop PC or any low-end laptop with dual or quad core CPU.

Waveguide Slot Array Simulation

The 10-element model is built by using the single slot model and applying a single *Copy* operation to create the other 9 array elements. The slots are positioned periodically at the points where surface currents would otherwise be longitudinal, at the upper side of the waveguide, one guide-wavelength apart. This distance enables in-phase excitation of all slots.

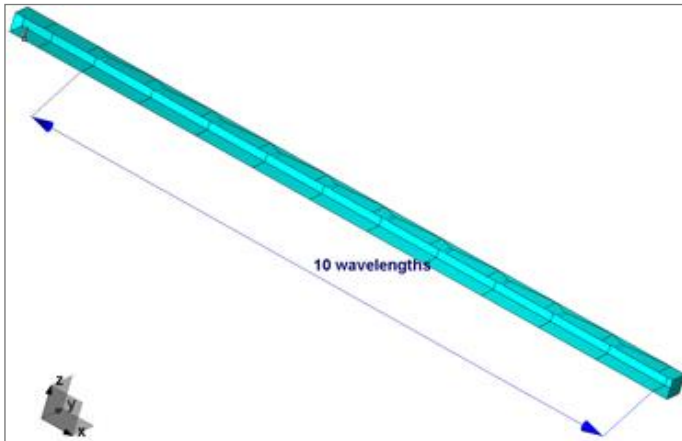

Fig.5. 10-element slot array model – one symmetry plane

The real part of the longitudinal component of the Poynting vector calculated along the axis of the waveguide shows the transfer of power from the generator to the slots, with a part of power being radiated at each slot (Fig.6). The markers designate the positions of the generator and the fifth slot.

The radiation pattern (in dBi) of the slot array is shown in Fig.7. The gain over 14 dBi and the radiation is broadside, with two pronounced grating lobes, which are expected since distance between array elements is one guide-wavelength.

The model of a 10-element slot array takes **only 1149 unknowns** (around 9 MB of RAM) for rigorous MoM simulation. The complete simulation, with calculation of radiation pattern in 32761 directions and near field in 470 points is **done in 2-3**

seconds, depending whether a standard desktop PC is used or a low-end laptop with dual or quad core CPU.

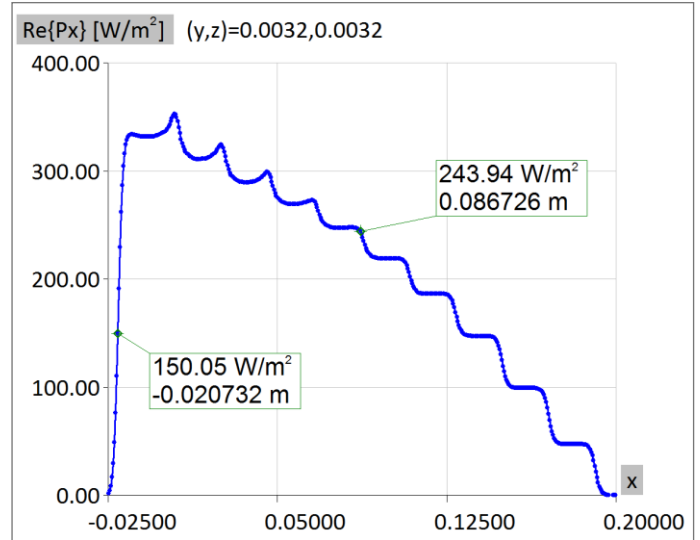

Fig.6. Real part of the Poynting vector longitudinal component along the axis of the waveguide (array)

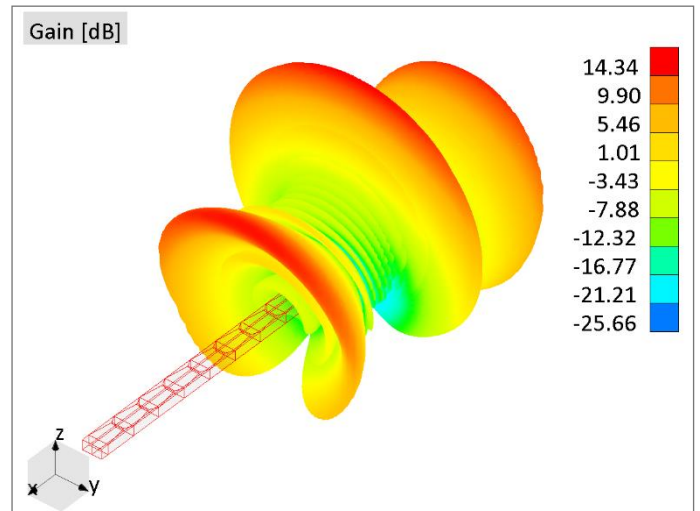

Fig.7. Radiation pattern of the array

